

Tolerances 1-20=+/-0.2 20-30=+/-0.3 30-40=+/-0.4 40-50=+/-0.5 50-100=+/-0.75 100-300=+/-1.5 Angles=+/-1 Dimensions are in Millimeters	Revisions	Approved	Date
	Description/Approved/Date	M.H.	5/28/04
		Checked	Date
	M.H.	5/28/04	
	Drawn	Date	
	M.D.L	5/28/04	
	NOTES (plating thickness in micro-inches): 1. Per QQ-B-626 2. Per QQ-S-764 3. Per QQ-C-530 4. Per QQ-B-750 5. Per MIL-P-19468 6. Per ZZ-R-765 7. Per WW-T-799 8. Gold pl. 5 min. over nickel pl. 50 min. over copper strike 9. Nickel pl. 100 min. over copper strike 10. Per QQ-P-35 11. Gold pl. 5 min. over nickel pl. 50 min. over copper strike		

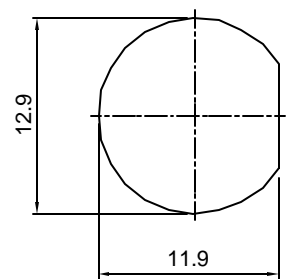

RECOMMENDED MOUNTING HOLE

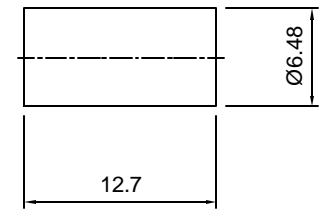
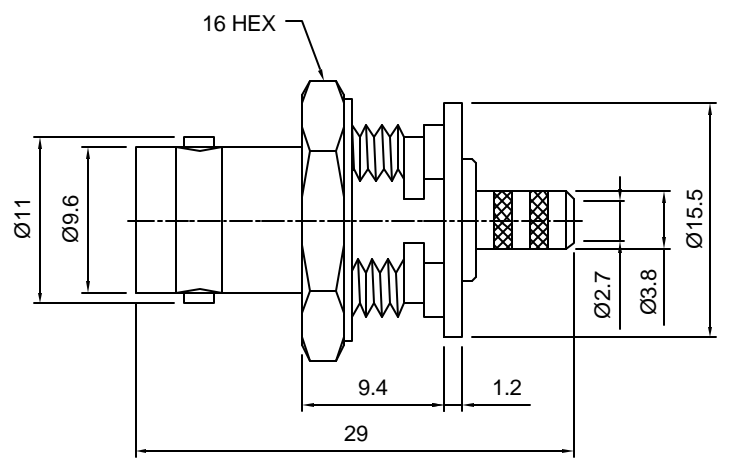

ITEM	MATERIAL	FINISH
Connector Body	Brass, Note 1	Nickel, Note 9
Center Contact: F	Brass, Note 1	Gold, Note 11
Insulation	Teflon, Note 5	None
Ferrule	Annealed Copper, Note 7	Same as body
Gasket	Silicone Rubber, Note 6	None
Hex Nut	Brass, Note 1	Same as body
Lock Washer	Same as body	Same as body

Lighthouse Technologies, Inc.
 4907 Morena Boulevard, #1411
 San Diego, California 92117

Part Number:
LTI-7BSF13RENT-179

Description		
75 ohm BNC crimp bulkhead rear mount, isolated jack		
for RG 179 cable. Nickel plated brass body, teflon dielectric.		
Scale	Drawing No.	File Name
2:1	7BSF13E-179	7BSF13E-179